

POS & Tradefood

Global Portfolio

2023



More than a moment

Preamble

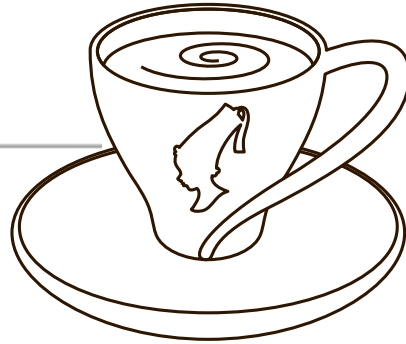

Objectives

- ❶ **Drive conversion & growth** by offering appealing POS & tradefood solutions.
- ❷ Strategically assess global (and local) POS & tradefood portfolio on a constant basis to
A) **find synergies** between local and global items and B)
detect need gaps and update offering to stay contemporary and competitive.
- ❸ Bring logic into portfolio by offering solutions from base to premium level.

Your responsibilities

Actively manage the portfolio and combine Premium POS items exclusively with Premium coffees.

Assess your local POS items on a regular basis. In case a global solution is available, phase out the local one and switch to the global item (higher cost synergies).

Provide global marketing with feedback on items and stick to process in case of complaints.

Keep your IVA-target in mind!

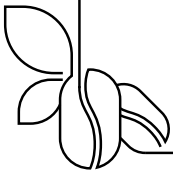

Cup & POS portfolio

OB guidance 2020 slide

Strategy

Continuous evaluation of global and local POS portfolio to **identify need gaps** vs. competitors and **find synergies** between items. Upgrade POS tools and innovate **to stay competitive and contemporary**.

Actions/Tactics

- Bring premium vs. standard logic into local POS portfolio (premium tools exclusively available for 1862 and super premium coffee customers)
- Global Marketing to work on 2nd wave of aligned POS updates focusing on barista tools to turn staff into brand advocates (tbd)
- Assess local portfolio keeping the IVA KPI in mind and follow PPP for local needs

Timing

ongoing

Objectives

- Drive conversion & growth by offering appealing POS solutions on all levels (base to premium).
- Grow brand awareness



- Whenever a similar global item is available, the local items needs to be phased out (exceptions: import restrictions, significant economical advantage)
- Working on relaunching POS items in 2022 does not necessarily mean launching in 2023 (depending on stock, duration of development process, sample approval)





Vienna
roast master



Overview



**Personal
service**

**Quality &
Expertise**



More than a moment

POS & Tradefood structure

POS

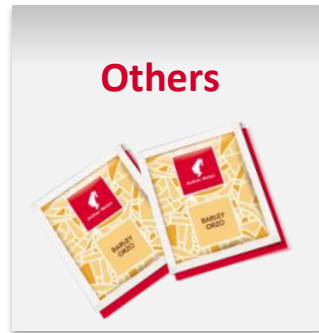
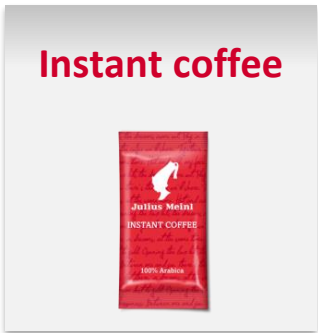
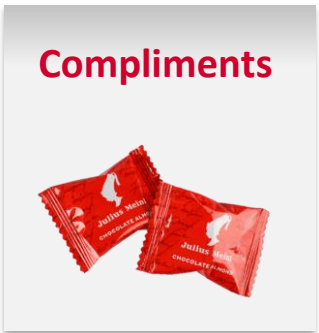
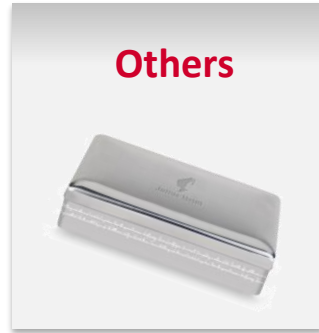
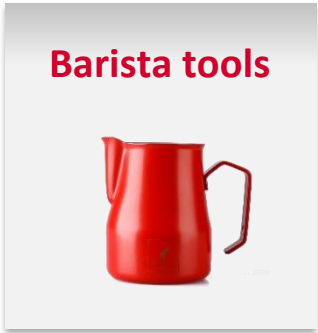
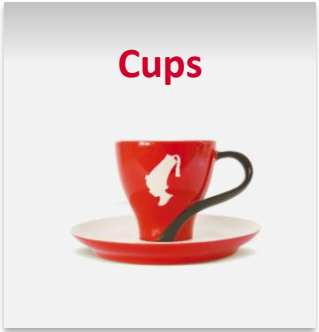

Tradefood



Vienna
roast master

POS items

**Personal
service**

**Quality &
Expertise**



More than a moment

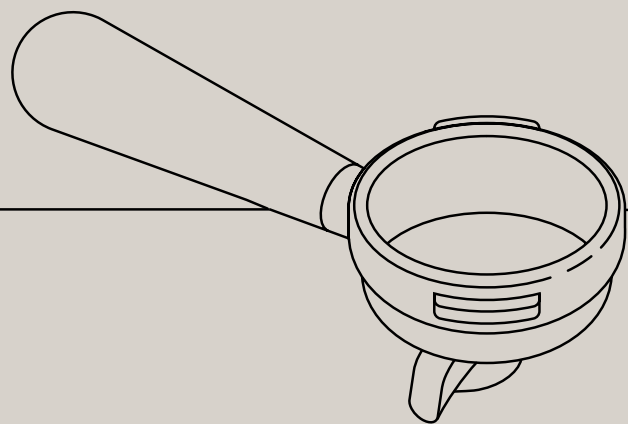

Cups



1862 Luxury line

(exclusively available with the 1862 concept)



Espresso cup

Art. No.: 93582

Fill. Cap.: 85 ml*



Melange cup

Art. No.: 93583

Fill. Cap.: 150 ml*



Tea/Cappuccino cup

Art. No.: 93584

Fill. Cap.: 180 ml*



Milk jug

Art. No.: 93585

Fill. Cap.: 40 ml*



Recommended
serving



*full to the brim

Trend line – iconic Matteo Thun cups

(to be used for luxury and super premium segment)



Espresso cup

Art. No.: 78187

Fill. Cap.: 85 ml*



Melange cup

Art. No.: 78186

Fill. Cap.: 150 ml*



Tea/Cappuccino cup

Art. No.: 78183

Fill. Cap.: 180 ml*



Jumbo cup

Art. No.: 78379

Fill. Cap.: 270 ml*



Milk jug

Art. No.: 78175

Fill. Cap.: 40 ml*



Recommended
serving



*full to the brim

Trend line – iconic Matteo Thun cups

(to be used for luxury and super premium segment)



Espresso cup

Art. No.: 88882

Fill. Cap.: 85 ml*



Melange cup

Art. No.: 88883

Fill. Cap.: 150 ml*



Tea/Cappuccino cup

Art. No.: 88885

Fill. Cap.: 180 ml*



Jumbo cup

Art. No.: 88884

Fill. Cap.: 270 ml*



Milk jug

Art. No.: 88886

Fill. Cap.: 40 ml*



Recommended
serving



*full to the brim

Premium Modern line

(solely to be used on luxury and super premium level)



Espresso cup

Art. No.: 93587

Fill. Cap.: 80 ml*



Melange cup

Art. No.: 93588

Fill. Cap.: 180 ml*



Tea/Cappuccino cup

Art. No.: 93589

Fill. Cap.: 290 ml*



The Originals line

(exclusively available with “The Originals Concept”)



Espresso cup

Art. No.: 88236

Fill. Cap.: 80 ml*



Melange cup

Art. No.: 88237

Fill. Cap.: 180 ml*



Tea/Cappuccino cup

Art. No.: 90566

Fill. Cap.: 290 ml*



Standard line – Red Saucer

(to be used for mainstream and premium segment)



Espresso cup

Art. No.: 87136

Fill. Cap.: 90 ml*



Melange cup

Art. No.: 87138

Fill. Cap.: 165 ml*



Tea/Cappuccino cup

Art. No.: 87139

Fill. Cap.: 240 ml*



Standard line

(to be used for base and mainstream segment)



Espresso cup

Art. No.: 80374
Fill. Cap.: 90 ml*



Melange cup

Art. No.: 80373
Fill. Cap.: 165 ml*



Tea/Cappuccino cup

Art. No.: 80375
Fill. Cap.: 240 ml*



Jumbo cup 1

Art. No.: 80660
Fill. Cap.: 230 ml*



Jumbo cup 2

Art. No.: 80372
Fill. Cap.: 320 ml*



Milk jug

Art. No.: 80727
Fill. Cap.: 40 ml



Tea Premium line

(to be used for premium segment)



Spirit tea pot

Art. No.: 83395
Fill. Cap.: 430 ml



Spirit tea cup

Art. No.: 83433
Fill. Cap.: 225 ml



Spirit tea cup lid

Art. No.: 83434



Saucer for tea filter*

Art. No.: 79496



Spirit milk/lemon jug

Art. No.: 82461
Fill. Cap.: 40 ml



**Recommended
serving**



*phase out, but still available, please order to deplete stocks

Tea Standard line

(to be used for base and mainstream segments)



Standard tea pot

Art. No.: 80728
Fill. Cap.: 400 ml



Tea/Cappuccino cup

Art. No.: 80375
Fill. Cap.: 240 ml



Jumbo cup 1

Art. No.: 80660
Fill. Cap.: 230 ml



Jumbo cup 2

Art. No.: 80372
Fill. Cap.: 320 ml

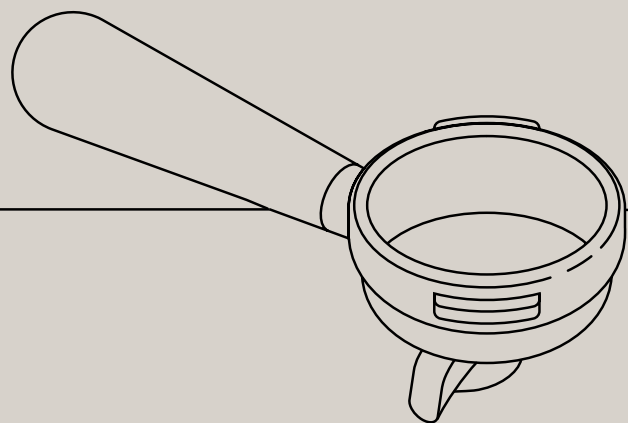

Glasses & Mugs

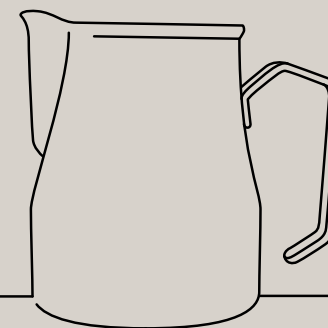

Glasses & Mugs



Latte glass

Art. No.: 253650

Fill. Cap.: 340 ml



Water glass

Art. No.: 78759

Fill. Cap.: 100 ml



Hipster glass*

(to be used for Cold Brew & Tea On The Rocks)

Art. No.: 92192

Fill. Cap.: 410 ml



Unbranded Water glass

Art. No.: 80577

Fill. Cap.: 100 ml



*phase out, but still available,
please order to deplete stocks

Glasses & Mugs



Leaf Bag glass*

Excl. Saucer

Art. No.: 87757

Fill. Cap.: 300 ml



Glass saucer

(for Latte & Leaf Bag glass)

Art. No.: 78384



Coffee/Tea/Chocolate Mug

Art. No.: 79643

Fill. Cap.: 320 ml



*phase out, but still available, please order to deplete stocks

*Design update as of February 2022 – professional product image will be provided at a later stage

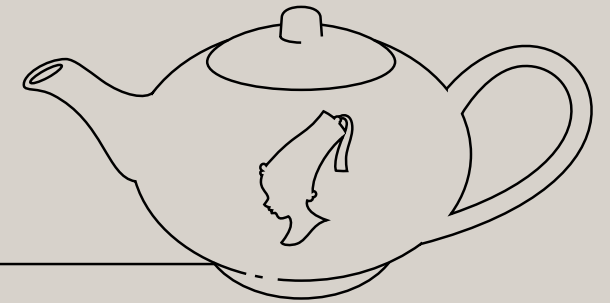

Tea POS



Tea displays



Single Bags Display
Art. No.: 88679



Big Bags Display
Art. No.: 88680



Tea displays



Leaf Bags Display
Art. No.: 87823



Loose tea tin
Art. No.: 94795



Loose tea Display
Art. No.: 95374



Tea presentation boxes



Tea presentation box

(fits Single Bags & Leaf Bags)

Art. No.: 77886

Big Bags presentation box

Art. No.: 86754

Tea presentation tools



Samovar 5l

Art. No.: 86756



Water kettle

Art. No.: 80779



Water kettle cover

Art. No.: 89809

Other tea POS



Tea on the rocks dispenser

Art. No.: 89436

Fill. Cap.: 8l



Permanent tea filter

Art. No.: 79495



Loose tea measuring spoon

Art. No.: 84647



Tea timer

Art. No.: 82428



Tea filter (changeable)

Art. No.: 79459



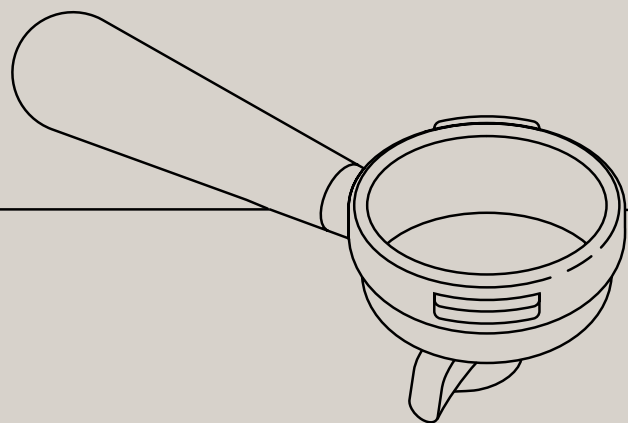

Outdoor Branding

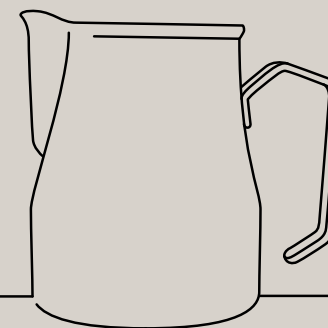

Light signs

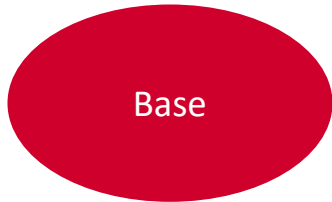

Double-sided light sign

Art. No.: 93775

Size: 50x50 cm



Single-sided light sign

Art. No.: 93776

Size: 50x50 cm



External light sign*

Art. No.: 195081



Super Premium Stone light sign**

Art. No.: 93472

Size: 35x25cm



*visualization only

**solely to be used on Luxury & Super Premium level

Outdoor branding tools

New Design



Sun umbrella cover (only)

Art. No.: 94920

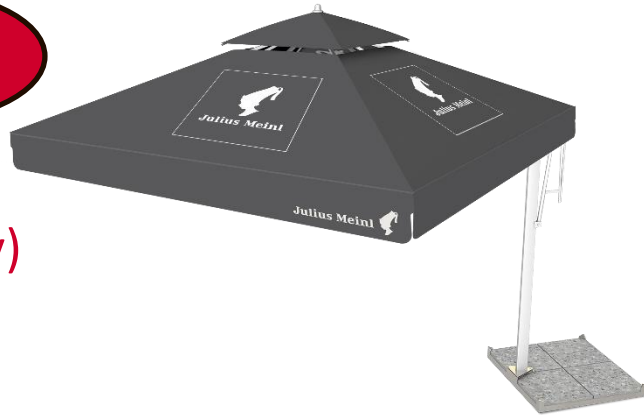

Sunshade big

Art. No.: 82880

Size: 3x3 m

Sunshade stand

excl. plates

Art. No.: 82881



New Design

Sunshade small

Art. No.: 82879



Plant pot*

Art. No.: 84537



A-Stand blackboard

Art. No.: 80630



*"Make to take" – item, ordered once per year

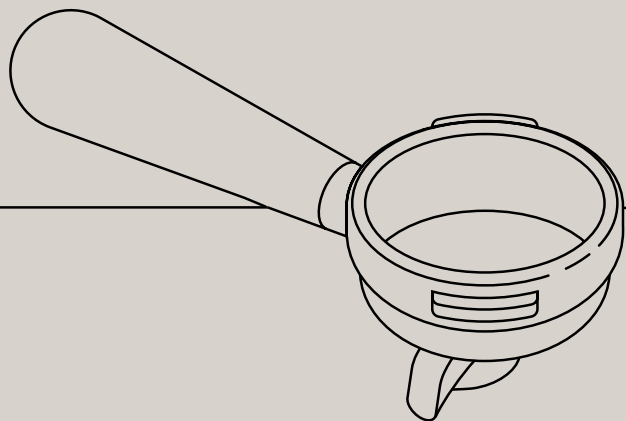

Indoor Branding

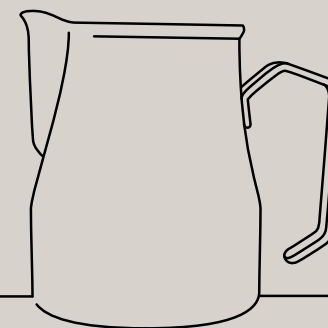

Signs



Plexi sign

(also suitable for outdoor branding)

Art. No.: 81269

Size: 50x50 cm



Lighted window sign

Art. No.: 93633

Size: 35x35 cm



Indoor branding tools



Tazzone/Sugar bags holder cup
Standard
Art. No.: 180550
Ø 15 cm



Tazzone/Sugar bags holder cup*
Trend
Art. No.: 86359
Ø 13 cm

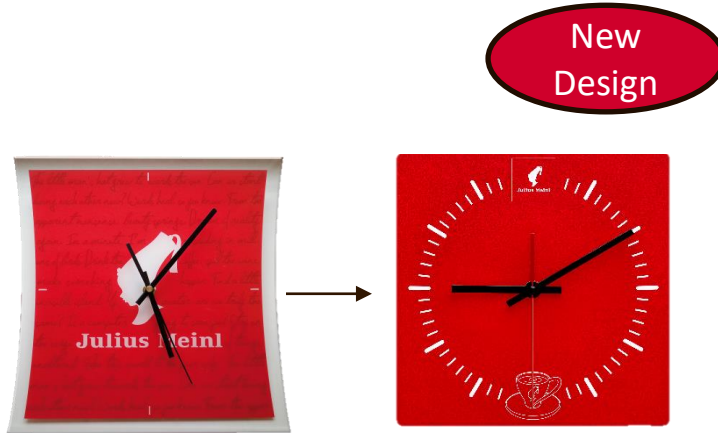

Clock**
Art. No.: 181325

Wooden Clock**
Art. No.: 181325



*cup has a hole in order to classify it as decorative item vs. real cup
**smooth switch when old stocks are depleted

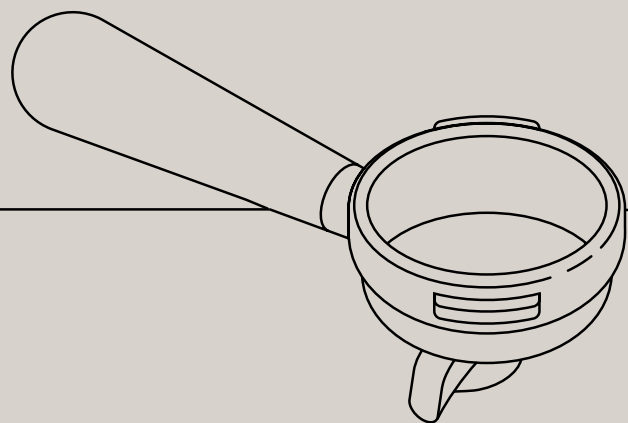

On the table



Sugar & Napkin holders



Base napkin holder
Art. No.: 93600



Poetry Napkin holder*
Art. No.: 87220



Wooden napkin holder
Art. No.: 87220

New Design

Premium



Base sugar holder
Art. No.: 93715



Poetry Sugar holder*
Art. No.: 87219



Wooden sugar holder
Art. No.: 87219

New Design



*smooth switch when old stocks are depleted

On the table



Napkin

Art. No.: 82798

Size: 15x15



Coasters

Art. No.: 78105



Napkin for napkin holder

Art. No.: 180994



French press timer*

Art. No.: 85553



Silver serving tray

Art. No.: 82797

Size: 28,7x22,1 cm



Black serving tray

Art. No.: 94091

Size: 28,7x22,1 cm



Serving tray (French press)*

Art. No.: 85554



*phase out, still stocks available, please use "timer" as a present or for sampling, serving tray can be used for different coffee serving purposes

On the table



Menu holder

Art. No.: 93601

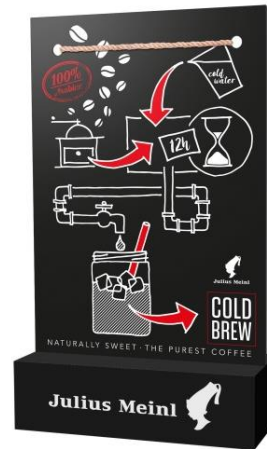

Cold Brew table tent for CB recipes

Art. No.: 88254



Cold Brew mini palette

Art. No.: 88196



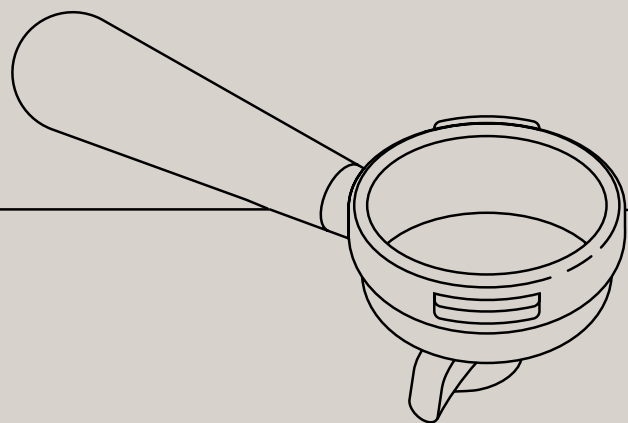

Coffee to go



C2G items



Wooden stirring sticks
(1.000 pcs / box)
Art. No.: 93627



Coffee to go lid
0.2l - Art. No.: 94521
0.3.l - Art. No.: 94522



Coffee to go lid*
0.1l - Art. No.: 94640



Biodegradable

Coffee to go cup

0.3l - Art. No.: 93625
0.2l - Art. No.: 93623
0.1l - Art. No.: 93621



*current version of 0.1 l lid is without drinking hole, the one with a drinking hole will be available as of 2nd HY 2022

C2G items



Permanent 2Go cup (r cup)*

Art. No.: 94667



*"Make to take" item

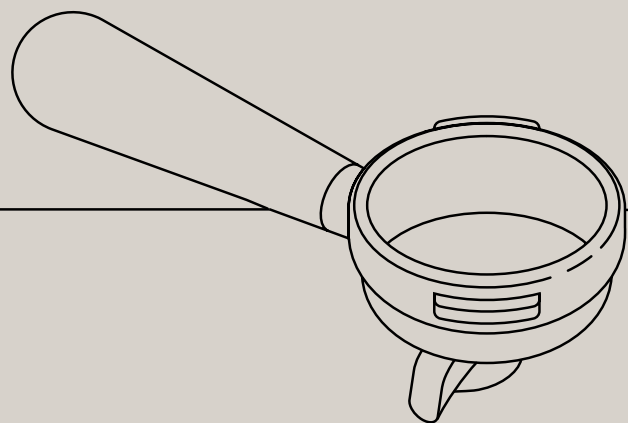

Barista tools

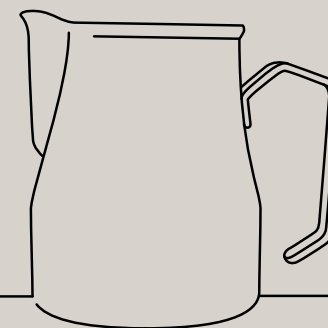

Barista tools



Hebeltamper (Press Tamper
with 2 plates, 52 & 57mm)
Art. No.: 82037



Tamping matt
Art. No.: 95231



Poetry tray large
Art. No.: 181503



Tamper 57/58mm
Art. No.: 80529



Tamping stand
Art. No.: 95232

Barista tools



Barista Milk Jug 0,35l

Art. No.: 93634



Barista Milk Jug 0,5l

Art. No.: 93635



Barista Milk Jug 0,75l

Art. No.: 93636

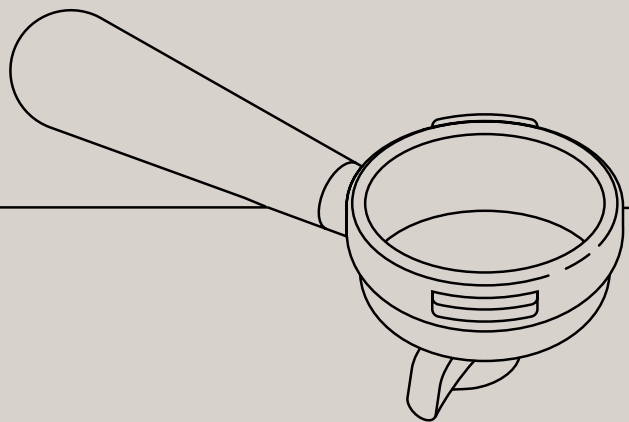

Clothing

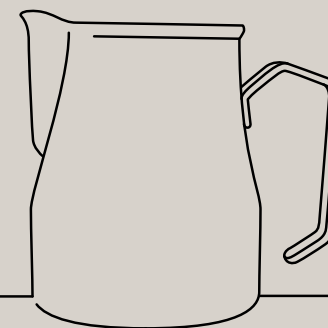

Aprons



The Originals apron*

Art. No.: 82944



Barista apron long

Art. No.: : 91781



Bistro apron short

Art. No.: 82945



*exclusively available with The Originals / New Wave coffee concept

Poloshirts



Polo shirt red**

Size S - Art. No.: 80564

Size M - Art. No.: 80561

Size L - Art. No.: 80562



Polo shirt white*

Size S - Art. No.: 78500

Size M - Art. No.: 78501

Size L - Art. No.: 78502

Size XL - Art. No.: 78503

*phase out, still stocks available

** updated design already available, however very large volumes are on stock from existing models, please help to deplete and use for promotions and product bundles

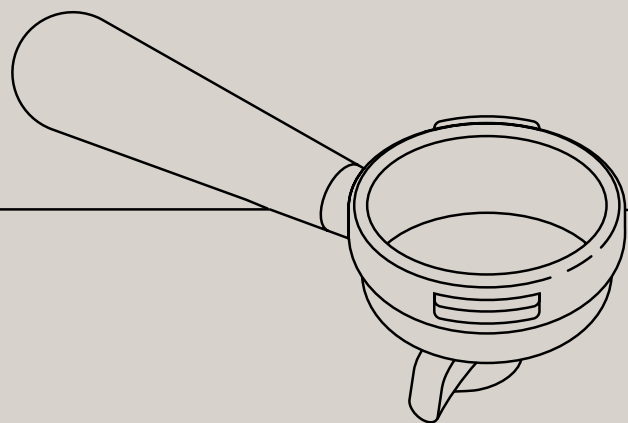

Others

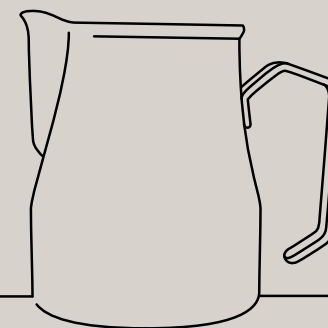

Boxes & Dispensers



Inpresso Professional
Capsule Dispenser

Art. No.: 88662



Hotel box*

Art. No.: 87285



Presentation box (French Press)*

Art. No.: 85555



Inpresso capsule book

(fits Inpresso and Inpresso
Professional capsules)

Art. No.: 88791

*phase out, still stocks available, please use for presentation purposes or presents to deplete stocks



Tins



Tin Elisabeth
(fits 500g ground coffee)
Art. No.: 82468

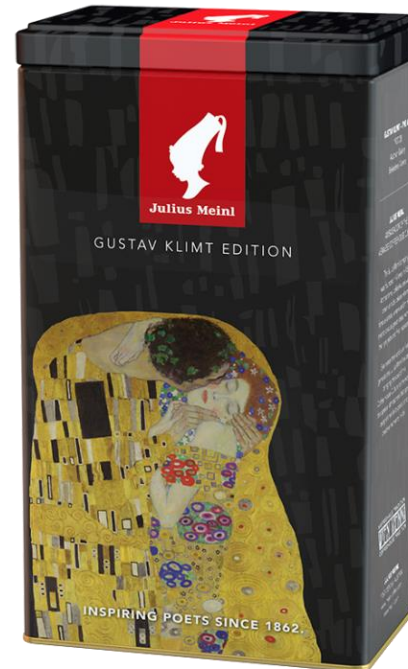

Tin Klimt
(fits 500g ground coffee)
Art. No.: 82467



Tin Vienna
(fits 250g ground coffee)
Art. No.: 94807



Vienna
roast master

Tradefood

Personal
service

Quality &
Expertise



More than a moment

Sugar & Sweeteners



Sweetener
Art. No.: 199059

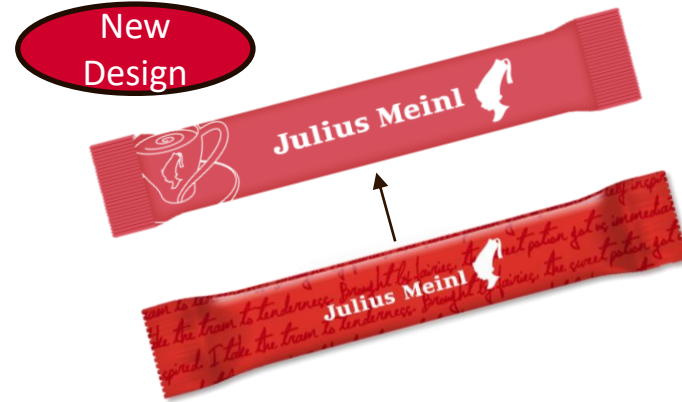

White Sugar Stick 1000* 3.6g*
Art. No.: 94809



Brown Sugar Stick 1000* 3.6g*
Art. No.: 94810

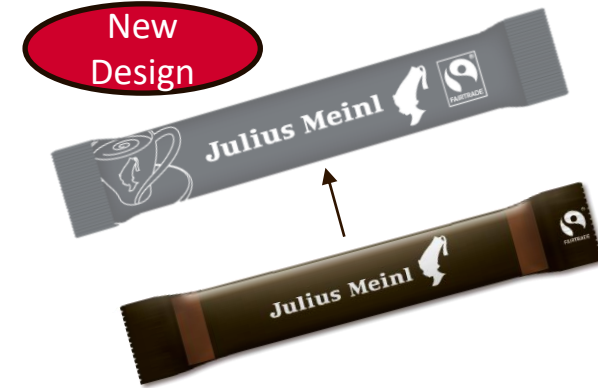

**Premium Brown Sugar Stick
Fairtrade 1000* 3.6g ***
Art. No.: 94812



Premium White Sugar Stick 3.6g**
Art. No.: 94811



*smooth switch when old stocks are depleted

**phase out

Compliments

New Design



Almond in cinnamon
250pc
Art. No.: 86803



Manner Biscuit
300pc
Art. No.: 88716

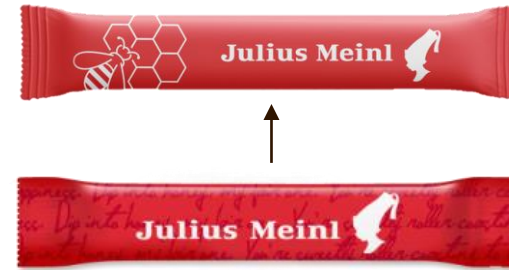

Honey Stick 15g*
Art. No.: 82882



Caramel Biscuit
Art. No.: 8596



Kandis sugar brown
Art. No.: 79124



Coffee Cream
300 x 8g
Art. No.: 11327



Coffee Cream 471ml
Art. No.: 80877



*smooth switch when old stocks are depleted

Drinking Chocolate



Chocolate Powder 18g

Art. No.: 79671



Chocolate Powder 1kg

Art. No.: 1235



Cocoa Mix 1kg

Art. No.: 77485



Drink Chocolate White

Art. No.: 93945



Chocolate Powder 300g

Art. No.: 79670



Moro Ciok
Drinking Chocolate 1kg

Art. No.: 199340



Moro Ciok
Drinking Chocolate (50 sachets)

Art. No.: 199320



Instant coffee



Instant Coffee 100g

Art. No.: 79801



Instant Coffee 2g
100% Arabica

Art. No.: 88115



Instant Coffee 2g
Decaf

Art. No.: 88116



Others



Barley sachets

Art. No.: 199621



Coffee whitener

Art. No.: 79838



Imperial de luxe 500g

Art. No.: . 80580